

Septic Tank Size (Gallons)	D(in)	H(in)	HI(in)	HO(in)	T(in)	FL(in)	Weight of Lid (lb)	Total Weight (lb)
200	40	48	43	40	3	38	325	1500
300	50	48	43	40	3	38	500	2000
500	56	68	63	60	3	58	635	3000
500 LP	72	44	40	36	3	34	1050	3450

*LP=Low Profile

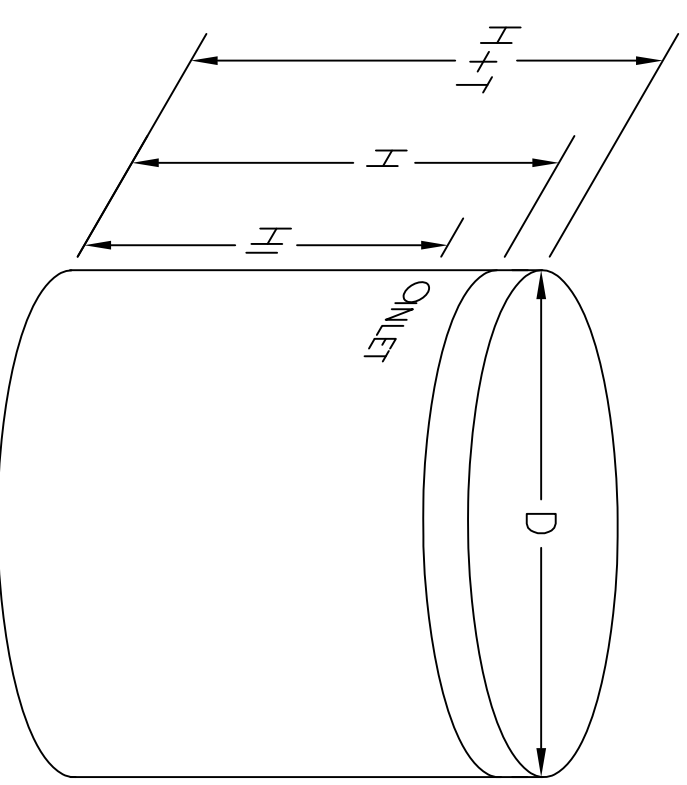

- General Notes:
1. All concrete shall have a mix design of 5000 PSI with a minimum of 5 sacks of standard Type 1 Cement
 2. All reinforcing bars shall be clean, new, and free of dirt, rust, or oil and shall meet or exceed the requirements of ASTM A-615M, Grade 60.
 3. Welded wire fabric shall be clean, new, and free of dirt, rust, or oil and shall meet or exceed the requirements of ASTM A-185.
 4. Lap rebars at all splices a minimum of 36 bar diameters.
 5. All reinforcing shall be set and tied, all concrete shall be placed, finished, and cured per ACI 318-83 specifications and per all safety provisions of OSHA.
 6. Wall and Btm. reinforcing shall be W1.4 by W1.4 on 6" centers.
 7. Top reinforcing shall be No. 3 bar on 9" center to center placed in the middle of concrete or an equal wire equivalent.
 8. Please excavate an additional foot around tank for installation.